

*TB 9-5210-209-24

DEPARTMENT OF THE ARMY TECHNICAL BULLETIN

CALIBRATION PROCEDURE FOR DEPTH GAGES (GENERAL)

Headquarters, Department of the Army, Washington, DC
18 June 2008

Distribution Statement A: Approved for public release; distribution is unlimited.

REPORTING OF ERRORS AND RECOMMENDING IMPROVEMENTS

You can improve this manual. If you find any mistakes or if you know of a way to improve these procedures, please let us know. Mail your letter or DA Form 2028 (Recommended Changes to Publications and Blank Forms) directly to: Commander, U.S. Army Aviation and Missile Command, ATTN: AMSAM-MMC-MA-NP, Redstone Arsenal, AL 35898-5000. A reply will be furnished to you. You may also send in your comments electronically to our E-mail address: 2028@redstone.army.mil or by fax 256-842-6546/DSN 788-6546. For the World Wide Web use: <https://amcom2028.redstone.army.mil>. Instructions for sending an electronic 2028 can be found at the back of this manual.

SECTION		Paragraph	Page
	I. IDENTIFICATION AND DESCRIPTION		
	Test instrument identification	1	2
	Forms, records, and reports.....	2	2
	Calibration description	3	2
	II. EQUIPMENT REQUIREMENTS		
	Equipment required	4	3
	Accessories required.....	5	3
	III. CALIBRATION PROCESS		
	Preliminary instructions.....	6	3
	Equipment setup	7	3
	Micrometer depth gage zero setting.....	8	4
	Micrometer depth gage calibration	9	5
	Micrometer depth gage lead angle	10	6
	Dial indicating depth gage zero setting.....	11	6
	Dial indicating depth gage calibration	12	8
	Vernier depth gage zero setting	13	10
	Vernier depth gage calibration.....	14	12
	Final procedure	15	12

*This bulletin supersedes TB 9-5210-209-35, dated 20 February 2004, including all changes.

SECTION I IDENTIFICATION AND DESCRIPTION

1. Test Instrument Identification. This bulletin provides instructions for the calibration of Depth Gages (General). The manufacturers' manuals were used as the prime data sources in compiling these instructions. The equipment being calibrated will be referred to as the TI (test instrument) throughout this bulletin.

a. Model Variations. Variations among models are described in text, tables, and figures.

b. Time and Technique. The time required for this calibration is approximately 1 hour, using the physical technique.

2. Forms, Records and Reports

a. Forms, records, and reports required for calibration personnel at all levels are prescribed by TB 750-25.

b. Adjustments to be reported are designated (R) at the end of the sentence in which they appear. When adjustments are in tables, the (R) follows the designated adjustment. Report only those adjustments made and designated with (R).

3. Calibration Description. TI parameters and performance specifications which pertain to this calibration are listed in table 1.

Table 1. Calibration Description

Test instrument parameters	Performance specifications
Micrometer type (with vernier):	
Thimble divisions ¹0.001 in.
Barrel Scale division ¹0.025 in.
Vernier divisions ¹0.0001 in.
Range: ¹0 to 1 in.
Accuracy:±0.0003 in.
Dial indicating type:	
Barrel scale divisions ¹0.0005 in.
Numbered divisions ¹0.005 in.
Range: ¹0 to 0.125 in.
Accuracy:±0.001 in.
Vernier type:	
Main scale divisions ¹0.025 in.
Vernier divisions ¹0.001 in.
Vernier scale ¹0.025 in.
Range (with additional scale): ¹0 to 12 in.
Accuracy:±0.001 in.
Micrometer type (without vernier):	
Thimble divisions ¹0.001 in.
Scale divisions ¹0.025 in.
Range: ¹0 to 6 in.
Accuracy:±0.001 in.

¹This specification is for information only and is not verified in this bulletin.

SECTION II EQUIPMENT REQUIREMENTS

4. Equipment Required. Table 2 identifies the specific equipment to be used in this calibration procedure. This equipment is issued with Secondary Transfer Calibration Standards Set AN/GSM-286; AN/GSM-287; or AN/GSM-705. Alternate items may be used by the calibrating activity. The items selected must be verified to perform satisfactorily prior to use and must bear evidence of current calibration. The equipment must meet or exceed the minimum use specifications listed in table 2. The accuracies listed in table 2 provide a four-to-one ratio between the standard and TI. Where the four-to-one ratio cannot be met, the actual accuracy of the equipment selected is shown in parenthesis.

5. Accessories Required. The accessories required for this calibration are common usage accessories, issued as indicated in paragraph 4 above, and are not listed in this calibration procedure.

Table 2. Minimum Specifications of Equipment Required

Common name	Minimum use specifications	Manufacturer and model (part number)
GAGE BLOCK SET	Range: 0.05 to 12 in. Accuracy: ± 0.000075 in. (0.000020 in., up to 1 in.; 0.000040 in. each additional in.)	7915946 7901372 7901961

SECTION III CALIBRATION PROCESS

6. Preliminary Instructions

a. The instructions outlined in paragraphs 6 and 7 are preparatory to the calibration process. Personnel should become familiar with the entire bulletin before beginning the calibration.

b. Items of equipment used in this procedure are referenced within the text by common name as listed in table 2.

c. Unless otherwise specified, verify the result of each test and, whenever the test requirement is not met, take corrective action before continuing with the calibration. Adjustments required to calibrate the TI are included in this procedure. Additional maintenance information is contained in the manufacturer's manual for the TI.

d. Unless otherwise specified, all controls and control settings refer to the TI.

7. Equipment Setup

a. Prepare a clean work area and allow equipment and TI to stabilize at room temperature for 1 hour.

b. Observe that the TI is free of nicks and burrs.

c. Check TI for freedom of operation.

(1) Rotate thimble of micrometer depth gages through its full range; the thimble should move freely and easily without backlash. Backlash may be checked by holding the base and observing that there is no movement when the thimble is pushed and pulled laterally.

(2) Main scales (blades) of vernier depth gages should move freely in their base section.

(3) The rod of dial indicating depth gages should move freely and return to stop position without hesitation.

8. Micrometer Depth Gage Zero Setting

a. Performance Check

(1) Turn thimble of TI counterclockwise until 0 to 1 inch rod recedes beyond working face of base (fig. 1).

(2) Place TI on triangular base component of gage block set.

(3) Turn thimble clockwise until rod makes contact with triangular base, or for three clicks of ratchet.

NOTE

Use light pressure to advance thimble so that the base of the TI is not lifted off gaging surface. The rod should be raised and lowered several times to insure that it has not overrun proper reading.

(4) The TI should indicate 0 ± 0.0003 inch (with vernier) or 0 ± 0.001 inch (without vernier).

(5) Check zero settings of rods other than 0 to 1 inch by placing appropriate size gage block between base of TI and triangular base.

NOTE

To change rods, remove knurled cap from end of thimble and clean. Insert rod through hole in thimble assembly. Replace and tighten cap.

b. Adjustments. Position adjusting nut on rods in accordance with manufacturer's instructions for zero indication. Special wrenches are supplied with micrometer depth gages.

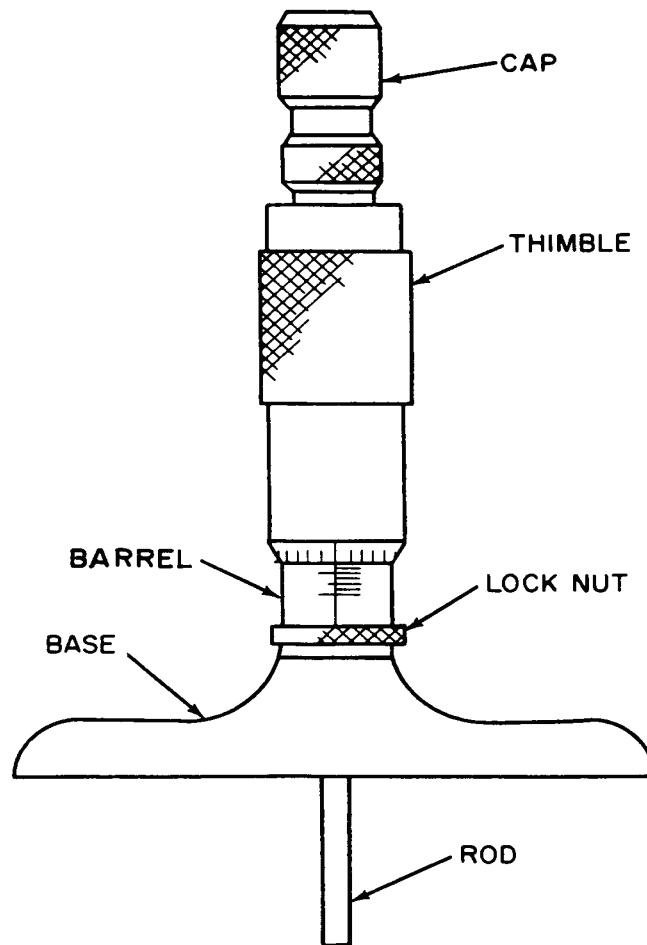

Figure 1. Micrometer depth gage.

NOTE

Measuring rods are matched to micrometers and are not interchangeable with rods of other micrometers.

9. Micrometer Depth Gage Calibration

a. Performance Check

(1) Set up micrometer depth gage with 0 to 1 inch rod, triangular base and 0.100 inch gage block.

(2) Wring 0.100 inch gage block to triangular base.

(3) While holding the base of TI firmly on gage block, place rod of TI over hole in the gage block and turn thimble of TI until rod makes contact with triangular base, or for three clicks of ratchet.

(4) The TI should indicate 0.100 ± 0.0003 inch (with vernier) or 0.100 ± 0.001 inch (without vernier).

(5) Repeat this check at 0.500 and 1 inch. The TI should indicate the nominal size of gage block used ± 0.0003 inch (with vernier) or ± 0.001 inch (without vernier).

NOTE

To check micrometer screw properly, all measurements must be computed from zero indication. Any deviation at zero must be taken into account at all checkpoints.

b. Adjustments. No adjustments can be made.

10. Micrometer Depth Gage Lead Angle

a. Performance Check

(1) Set up equipment as in **9 a** (1) above.

(2) Repeat **9 a** (2) through (5) above, using gage blocks which differ in size by 0.008 inch (approximately $\frac{1}{3}$ revolution of thimble).

b. Adjustments. No adjustments can be made.

11. Dial Indicating Depth Gage Zero Setting

a. Performance Check

NOTE

Dial indicating depth gages are of two general types: one type with the plunger normally retracted into the base and one with the plunger normally extended from the base.

NOTE

All measurements are relative to the base and must be zero set accordingly.

(1) Flat base normally extended type (fig. 2).

(a) Press TI down on triangular base until TI makes contact.

(b) Rotate bezel of indicator until pointer indicates 0. Lock bezel in place.

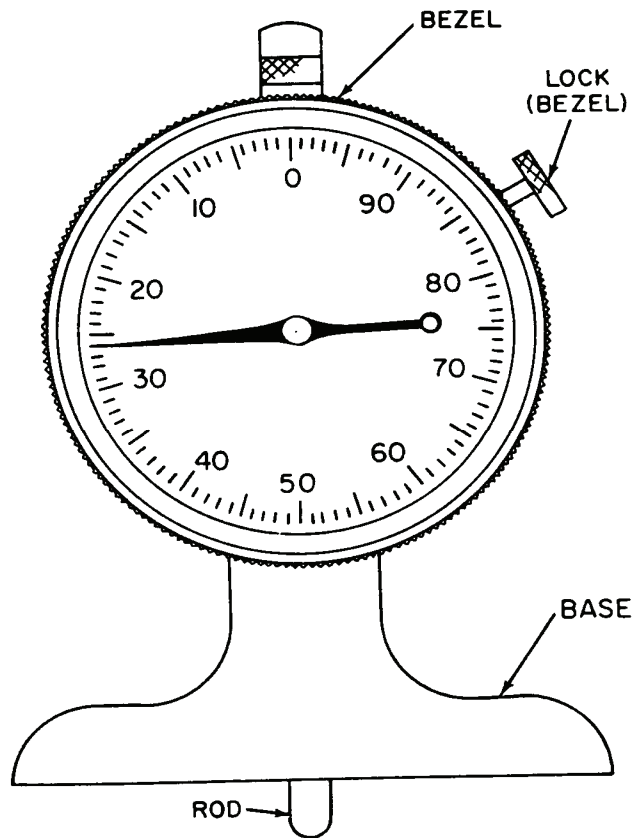

Figure 2. Flat base normally extended dial indicating depth gage.

- (2) Knife edge normally retracted type (fig. 3).
- (a) Place knife edge of TI on triangular base.
 - (b) Press down on push button of indicator until needlepoint contacts triangular base.
 - (c) Rotate bezel until indicator pointer is on 0. Lock bezel in place.

NOTE

The TI must be perpendicular to the gaging surface to obtain proper measurements. Check by rocking TI slightly while maintaining light pressure on point of the knife edge in contact with gaging surface. Read indicator where pointer deflects maximum clockwise or counterclockwise.

b. Adjustments. No further adjustments can be made.

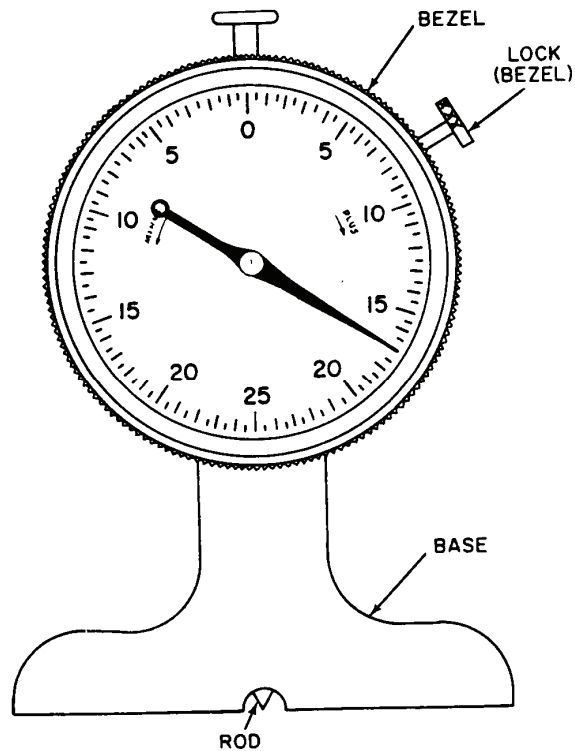

Figure 3. Knife edge normally retracted dial indicating depth gage.

12. Dial Indicating Depth Gage Calibration

a. Performance Check

NOTE

Some dial indicating depth gages can be calibrated more conveniently using dial indicator calibrator MIS-10327 and TB 9-5210-210-50.

(1) Set up triangular base and three sets of gage blocks to measure a depth of 0.010 inch (fig. 4 and table 3) and for $\frac{1}{2}$ inch depth gage (fig. 5 and table 4). Only center group of blocks need to be changed.

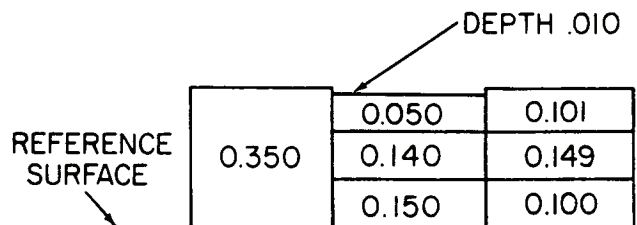

Figure 4. Dial indicating depth gage calibration.

Table 3. Combinations of Gage Blocks for Depths Specified

Depth (inch)	Center group combinations		
0.020	0.050	0.150	0.130
0.030	0.050	0.150	0.120
0.040	0.050	0.150	0.110
0.050	0.050	0.140	0.110
0.060	0.150	0.140	
0.070	0.150	0.130	
0.080	0.150	0.120	
0.090	0.150	0.110	
0.100	0.140	0.110	
0.110	0.130	0.110	
0.120	0.120	0.110	
0.125	0.120	0.105	

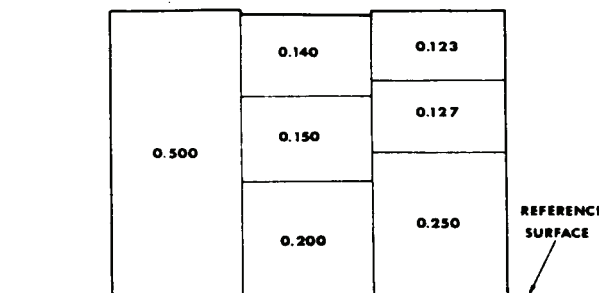

Figure 5. Dial indicating depth gage calibration.

Table 4. Combinations of Gage Blocks for Depths Specified

Depth (inch)	Center group combinations		
0.020	0.200	0.150	0.130
0.030	0.200	0.150	0.120
0.040	0.200	0.150	0.110
0.050	0.200	0.150	0.100
0.060	0.200	0.140	0.100
0.070	0.200	0.130	0.100
0.080	0.200	0.120	0.100
0.090	0.200	0.110	0.100
0.100	0.300	0.100	
0.110	0.150	0.140	0.100
0.120	0.150	0.130	0.100
0.125	0.150	0.125	0.100
0.250	0.150	0.100	
0.375	0.125		
0.500			

(2) The dial indicating depth gage should indicate 0.010 ± 0.0005 inch. Repeat this check, using the combination of gage block depth specified in table 3.

(3) On dial depth gages ranging up to $1/2$ inch, wring additional blocks totaling 0.150 inch to each side of center group. Dial should indicate 0.160 ± 0.0005 inch. Add 0.100 and 0.050 inch gage blocks to center group to obtain indications of 0.060 inch and 0.010 ± 0.005 inch, respectively.

- (4) Repeat this check using the combinations of gage block depth specified in table 4.

b. Adjustments

- (1) Retract the point of rod beyond the knife edge.
- (2) Depress the depth button to its limit. The indicator pointer should move 0.125 inch past zero-set position before making contact with internal mechanical stops.
- (3) Loosen screw at back of base assembly and reposition base assembly toward or away from indicator to achieve above condition.
- (4) Tighten screw and repeat calibration checks.

CAUTION

Do not overtighten screw on back of base assembly.

NOTE

Adjustment cannot be made to dial indicating depth gages for inaccuracies. Springs are used for return and anti-backlash only. Accuracy is dependent on quality of gears rack, pinions, bearings, etc., and is not adjustable. Indicators are interchangeable with any other standard American gage design indicator.

13. Vernier Depth Gage Zero Setting

a. Performance Check

- (1) Retract measuring end of main scale beyond edge of base. See fig. 6 for location of component parts.
- (2) Set base of TI on triangular base.
- (3) Advance main scale until it makes contact with triangular base. Lock main scale in place.
- (4) The vernier depth gage should indicate zero.

b. Adjustments. Loosen screws which fasten vernier scale to base assembly. Move vernier scale until zero line of vernier scale is in exact coincidence with zero line of main scale and the 25th line of the vernier scale is in exact coincidence with a line on the main scale. Tighten screws and recheck zero setting.

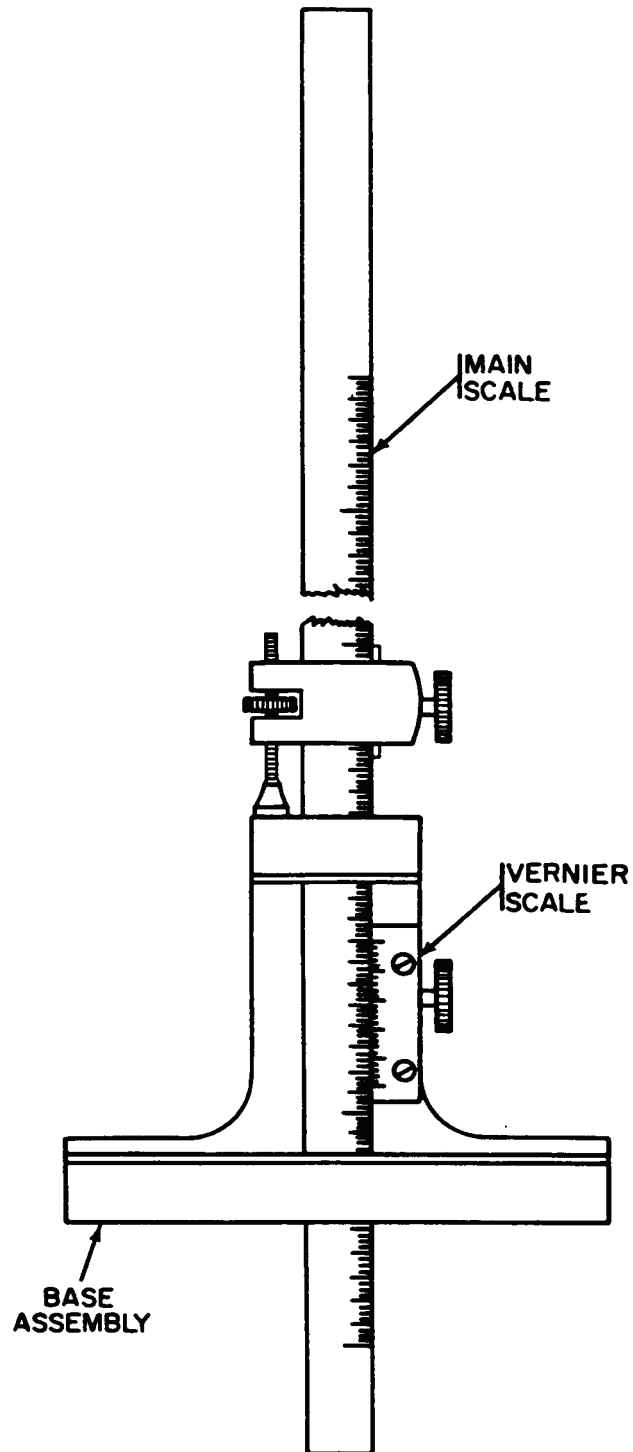

Figure 6. Vernier depth gage.

14. Vernier Depth Gage Calibration

a. Performance Check

- (1) Set up two groups of gage blocks 1 inch high on triangular base.
- (2) Set base of TI on gage blocks with main scale of TI between them.
- (3) TI should indicate 1.000 ± 0.001 inch.
- (4) Repeat this check at 1.0000 inch intervals to full scale.

b. Adjustments. No adjustments can be made.

15. Final Procedure

a. Multiple rods included in a set may be protected from rust with light oil and sealed in polyethylene material. Upon recalibration of the set, those rods with unbroken seals and no evidence of damage or deterioration do not require recalibration.

b. Annotate and affix DA label/form in accordance with TB 750-25.

By Order of the Secretary of the Army:

Official:

GEORGE W. CASEY, JR.
General, United States Army
Chief of Staff

A handwritten signature in black ink that reads "Joyce E. Morrow". The signature is written in a cursive style with a large, stylized initial "J".

JOYCE E. MORROW
Administrative Assistant to the
Secretary of the Army

0811206

Distribution:

To be distributed in accordance with initial distribution number (IDN) 342082, requirements for calibration procedure TB 9-5210-209-24.

Instructions for Submitting an Electronic 2028

The following format must be used if submitting an electronic 2028. The subject line must be exactly the same and all fields must be included; however, only the following fields are mandatory: 1, 3, 4, 5, 6, 7, 8, 9, 10, 13, 15, 16, 17, and 27.

From: "Whomever" whomever@redstone.army.mil

To: <2028@redstone.army.mil

Subject: DA Form 2028

1. **From:** Joe Smith
2. **Unit:** home
3. **Address:** 4300 Park
4. **City:** Hometown
5. **St:** MO
6. **Zip:** 77777
7. **Date Sent:** 19-OCT-93
8. **Pub no:** 55-2840-229-23
9. **Pub Title:** TM
10. **Publication Date:** 04-JUL-85
11. **Change Number:** 7
12. **Submitter Rank:** MSG
13. **Submitter FName:** Joe
14. **Submitter MName:** T
15. **Submitter LName:** Smith
16. **Submitter Phone:** 123-123-1234
17. **Problem:** 1
18. **Page:** 2
19. **Paragraph:** 3
20. **Line:** 4
21. **NSN:** 5
22. **Reference:** 6
23. **Figure:** 7
24. **Table:** 8
25. **Item:** 9
26. **Total:** 123
27. **Text**

This is the text for the problem below line 27.

